



OTS SERVICE AND SUPPLY COMPANY LIMITED



Engineering Service



Lubrication System

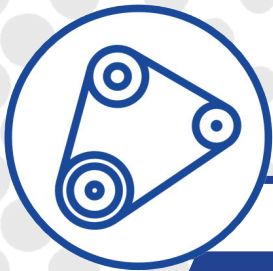

Belts Supply and Service



WWW.OTSINDUSTRIAL.COM



INTRODUCTION

OTS SERVICE & SUPPLY CO.,LTD was established since 2007, starting from humble beginning of supply lubrication systems to Thailand markets. The success was contribute to believe in customer service, our vision & mission. Since then OTS become well known named in industries for distribution & service for lubrication system & power transmission products.



Head Office

เลขที่ 66/1 หมู่ 11 ตำบลบางพระ
อำเภอศรีราชา จังหวัดชลบุรี 20110
โทร-033-098295, 099-1499984
E-mail: admin@ots-belts.com
Website: www.otsindustrial.com
Line Official: @ots-belts

Ayutthaya Branch

เลขที่ 90 หมู่ 5 ตำบลบ้านกรด อำเภอบางปะอิน
จังหวัดพระนครศรีอยุธยา 13160
โทร-035-200211, 086-3939064
E-mail: ots.ayutthaya@gmail.com
Website: www.otsindustrial.com



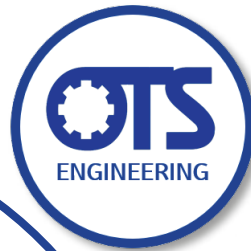

*OTS Engineering &
Construction Service*



*Gates Transmission
V-Belts & Timing Belt*



*Memolub Automatic
Lubrication System*



*Graco Lubrication
High Quality System*



Our service includes

- ผู้แทนจำหน่ายสายพานอุตสาหกรรม "GATES"
- ผู้แทนจำหน่ายระบบหล่อลื่นเครื่องจักร "MEMOLUB"
- ผู้แทนจำหน่ายระบบหล่อลื่นเครื่องจักร "GRACO"
- Power Transmission Solution.
- Machine installation.
- Piping and Insulation work.
- Tank Fabrication work.
- Structure Design & installation.
- Electrical work.
- Ducting work.



OUR CUSTOMERS



bangchak



SANKO



THAI SUMMIT GROUP



DSG



เมiji-เมiji



ปูนซีเมนต์เอเชีย
Asia Cement





CERTIFICATE OF DISTRIBUTORSHIP



THIS IS TO CERTIFY THAT

OTS SERVICE AND SUPPLY CO.,LTD.

377/273 Moo.2 Surasak, Sriracha, Chonburi 20110 Thailand

is the Authorized Distributor
for Power Transmission Industrial Belts in Thailand
from January 1, 2023 to December 31, 2023



Joyce Lim
Managing Director - South East Asia





Hi-Power II® V-Belts

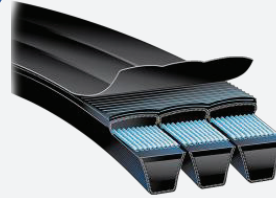

**Hi-Power II®
PowerBrand® Belts**



**Vulco Power™-II
JIS-(Red Lable)
Belts**



**Vulco Power™-II
RMA-(Yellow Lable)
Belts**

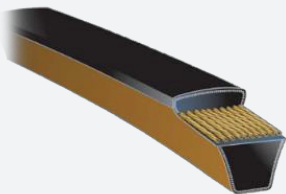

Predator®-Belts



**Super HC® Belts
Metric**



**Super HC® Belts
RMA**

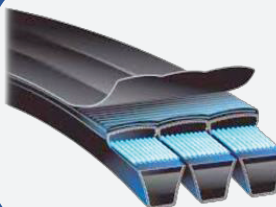

**Super-HC®
PowerBand®-Belts
Metric**



**Super HC® Belts
RMA**

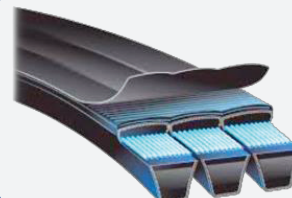

**Super-HC®
PowerBand®-Belts
RMA**

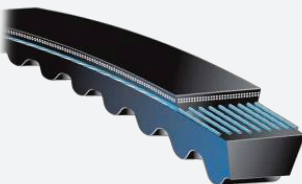

Tri-Power®-Belts

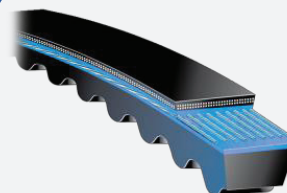

**Quad-Power®-4
Single-Belts**

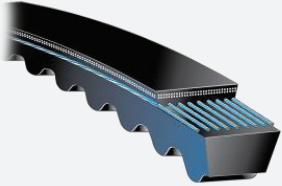

**Super-HC[®]
Plus-Vextra Belt**

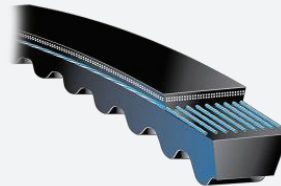

**Super-HC[®]
Molded-Notch
Single-Belts**

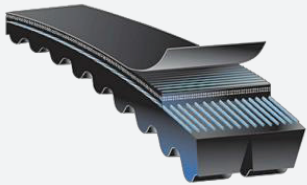

**Super-HC[®]
Molded-Notch
PowerBand[®]-Belts**



Micro-V[®]-Belts

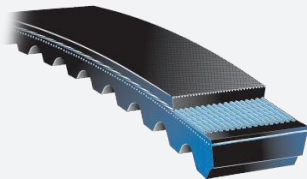

**Multi-Speed[®]
Belts**

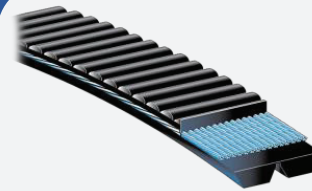

**Polyflex[®]
Single-Belts
Polyflex[®]-JB[®]-Belts**

V-Belt Pulley for Taper Bush & QD Bush



Available in 3V, 5V, 8V and
SPZ, SPA, SPB, SPC sections.



TIMING BELT



Poly-Chain®-GT®-Carbon™-& Poly-Chain®-Carbon™-Volt®

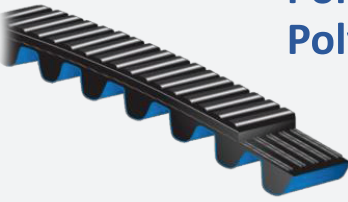

Available in
8MGT, 14MGT and 8MGTV, 14MGTV Profile.



PowerGrip®-Timing-Belts

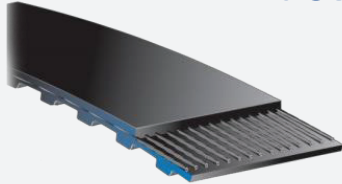

Available in XL, L, H, XH, XXH and T10 Profile.



PowerGrip®-Timing-Belts

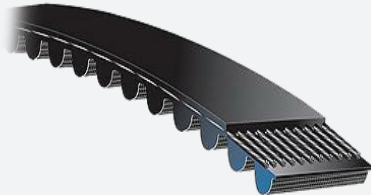

Available in 3M, 5M, 8M and 14M Profile.



Long-Length-PowerGrip®-Timing,-HTD® Belt Steel Cord and Glassfibre Cord



Available in 8M and 14M Profile.



PowerGrip®--Twin-Power®-Timing-Belts



Available in 5M, 8M and 14M Profile.





TIMING BELT



PowerGrip®-GT®4-Belts

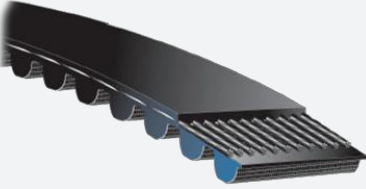

Available in 8MGT and 14MGT Profile.



PowerGrip®-GT2-Twin-Power®Belt



Available in 8MGT and 14MGT Profile.



Synchro-Power®-Polyurethane-Timing-Belts

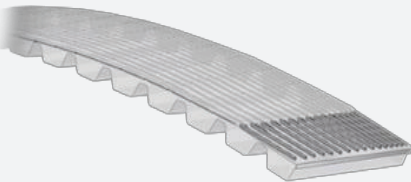

Available in
MXL, XL,L, T5 and T5, T10, T20 Profile.



Synchro-Power®-Polyurethane-Timing-Belts

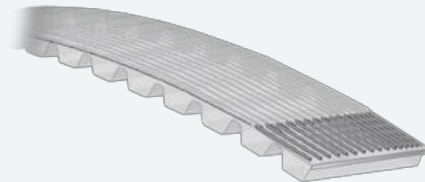

Available AT5, AT10 and AT20 Profile.



PowerGrip®--Twin-Power®-Timing-Belts Steel Cord and Glassfibre Cord



Available in
T5, T10, AT5, AT10 and MXL, XL, L Profile.



Poly-Chain®GT®2 Sprockets

Use with Poly Chain GT Carbon Belts



PowerGrip®GT®2 Sprockets

Use with PowerGrip GT3 and GT4 Belts



PowerGrip®HTD Sprockets

Use with PowerGrip HTD Belts

Available in 5M, 8M, 14M and 8MGT and 14MGT Profile.



Bushings

- A System for mounting a sheave or sprocket to a wide range of shaft sizes quickly and inexpensively
- Common Bushing Systems
 - QD (Quick Detachable) System
 - TL (Taper-Lock)* System

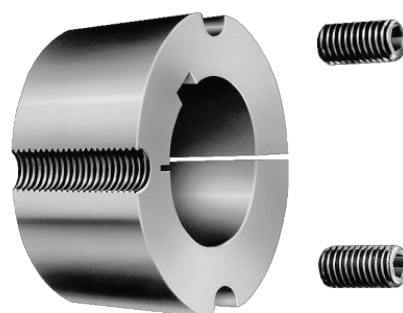



POWER TRANSMISSION TOOLS



V-Belt Pulley Gauges



Unitta Sonic Tension Meter U550



EZ Align Precision Laser Tool

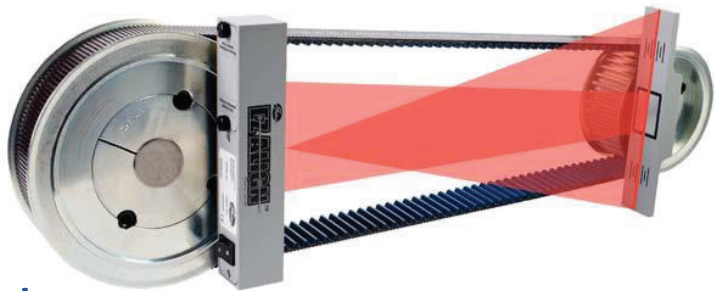

Tension Testers
30 Lbs



Tension Testers
66 Lbs



Tension Testers
165 Lbs





Belt Drive Improving & Energy Saving

Upgrade Belts Drive Improving Machine Efficiency Energy Saving

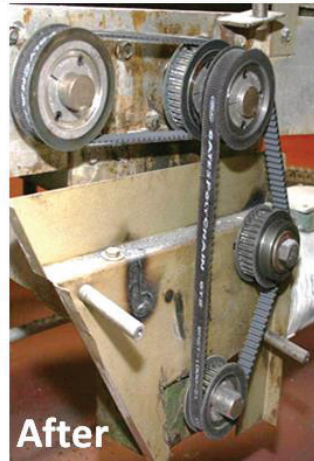
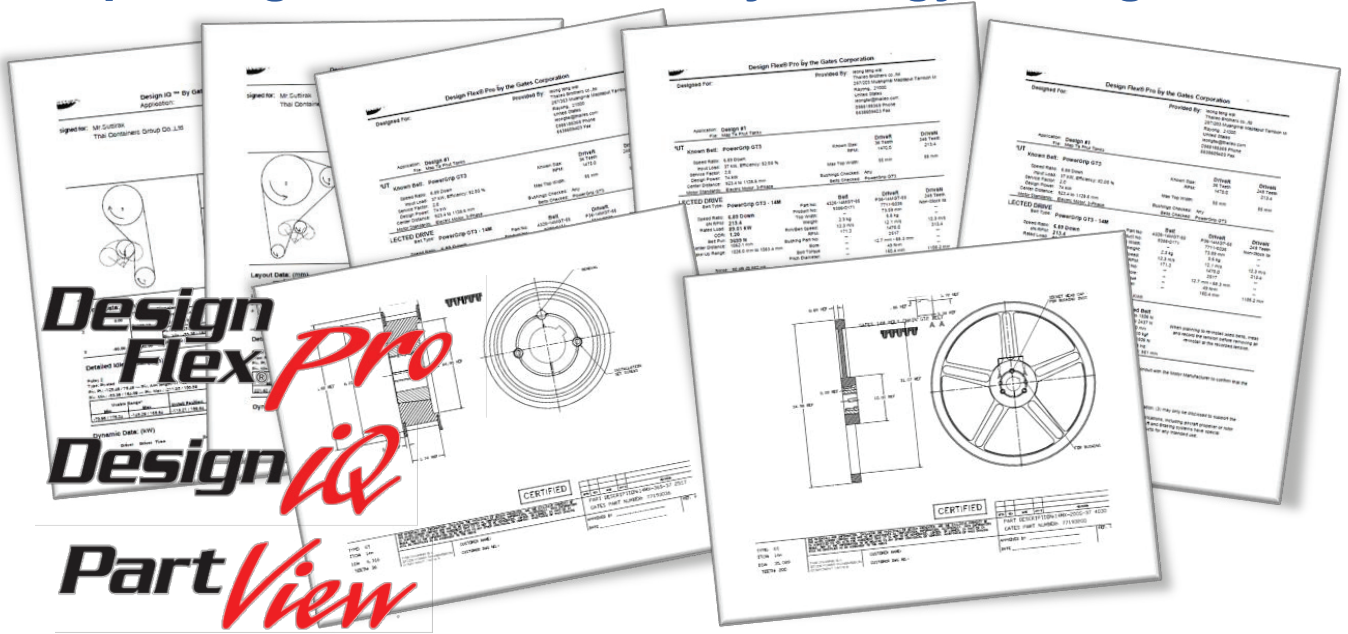

Motor 30 kw
V-Belts C-125 5 pcs
Pulley Driver 5-SPC-230 Weight 16.6 kg
Pulley Driven 5-SPC-650 Weight 73 kg
Top Width 136 mm

Motor 30 KW
Poly Chain GT Carbon Belt 14MGT-2600-37
Sprocket Driver 14MX-315-37 Weight 2.7 kg
Sprocket Driven 14MX-905-37 Weight 24 kg
Top Width 53.69 mm

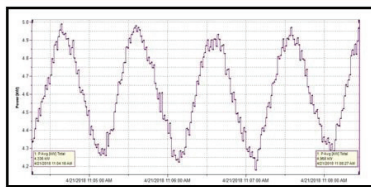
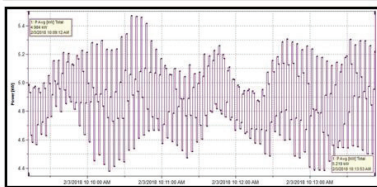

**Quality
Ethics & Integrity
Safety
Standard**





G-Mini Compact



G3 STANDARD



G3 PRO



G3 MAX

Up to 5100 psi / 352 bar

- Delivering full performance with NLGI #2 grease, also for Oil

AC and DC Power Models

- 12/24VDC and 90-240VAC deliver same industry leading performance

Up to Three Pumps

- Ability to meet both small and large system output requirements

Adjustable Output Pumps

- Three output settings allow you to size the system to meet specific lube requirements

Three Control Choices

- Use customer's PLC, establish a timed lube cycle, or use the Max Control to create a custom fit

Multiple Reservoir Sizes

- Five sizes enable you to meet specific application requirements

Two Reservoir Types

- Stirring paddle with wiper arm keeps grease from separating
- Follower plate with stirring paddle for extreme angle operation

Multiple Fill Ports

- Three fill ports allow you to install multiple connection types on the same unit. Oil fill port on top.

Flexible System Types

- Ready to use with both series progressive or injectors



Data Management System

- Track critical pump data for easy lube system diagnostics (USB)





CENTRALIZED LUBRICATION SYSTEM



Choose automatic lubrication and bid farewell to risks and other challenges related to manual lubrication:

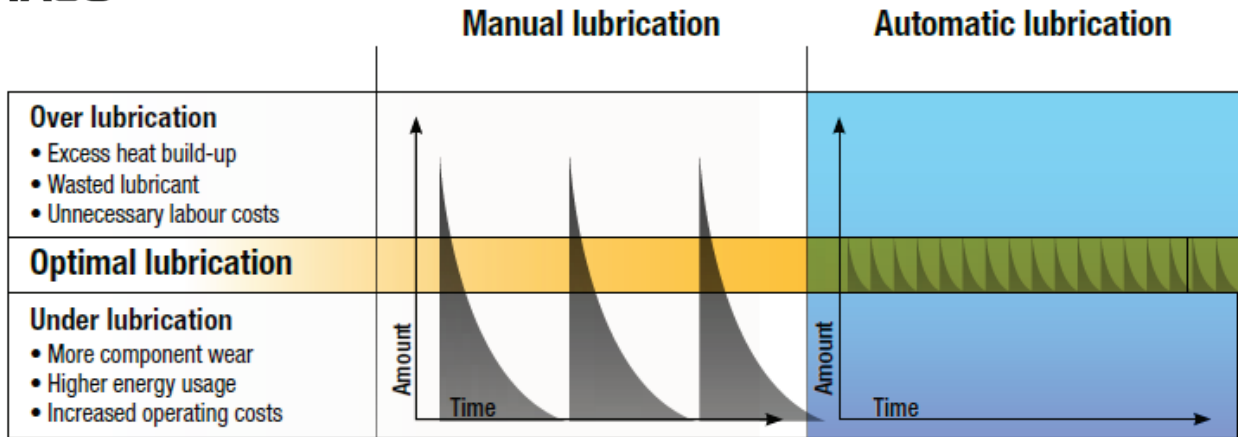

AN EXAMPLE: Infrequent filling of the bearing results in periods of over and under lubrication

AN EXAMPLE: Maintain optimal lubrication by replenishing only the lubricant that is used, with small amounts at frequent intervals



Series progressive automatic lubrication systems

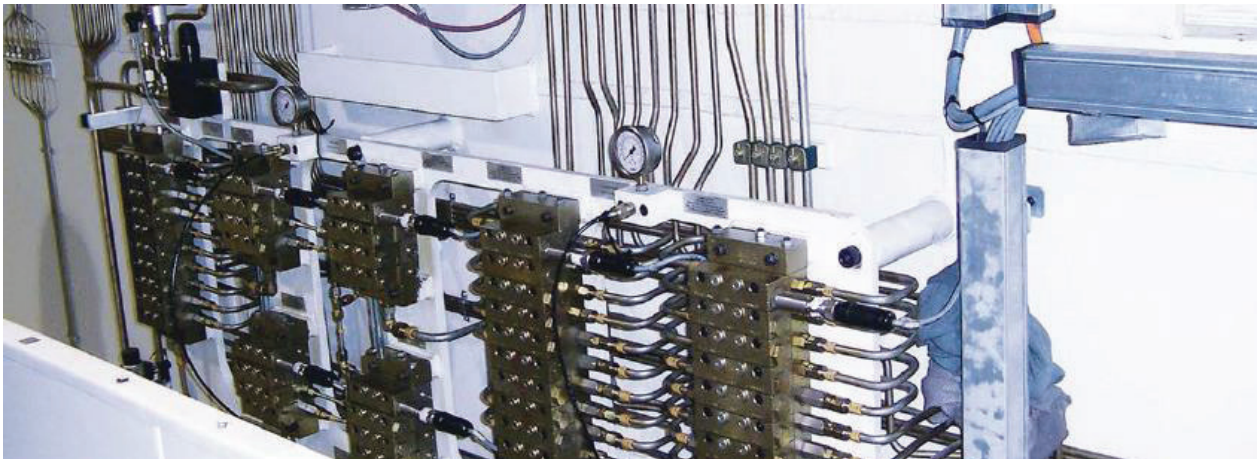

Components of a series progressive automatic lubrication system

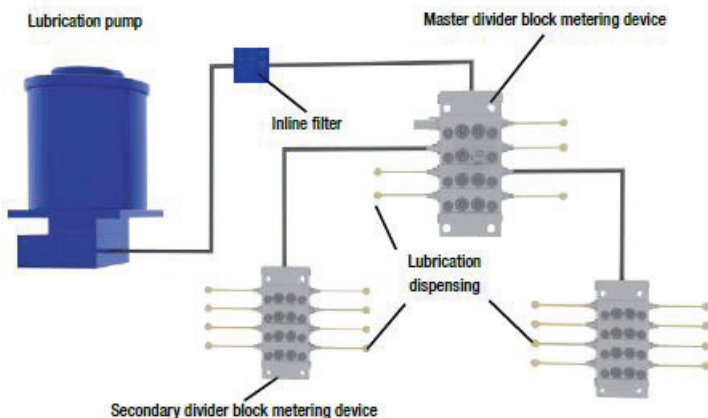

PUMPS & RESERVOIRS:
store and provide the lubricant to the system

CONTROLLER:
activates the system

DIVIDERS:
dispenses the right amount of lubricant to the lubrication point.



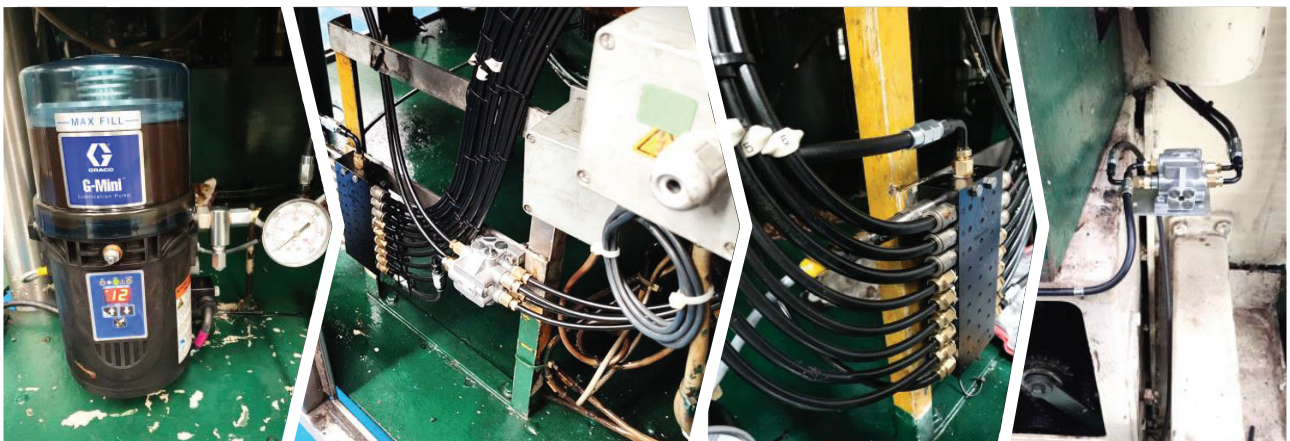
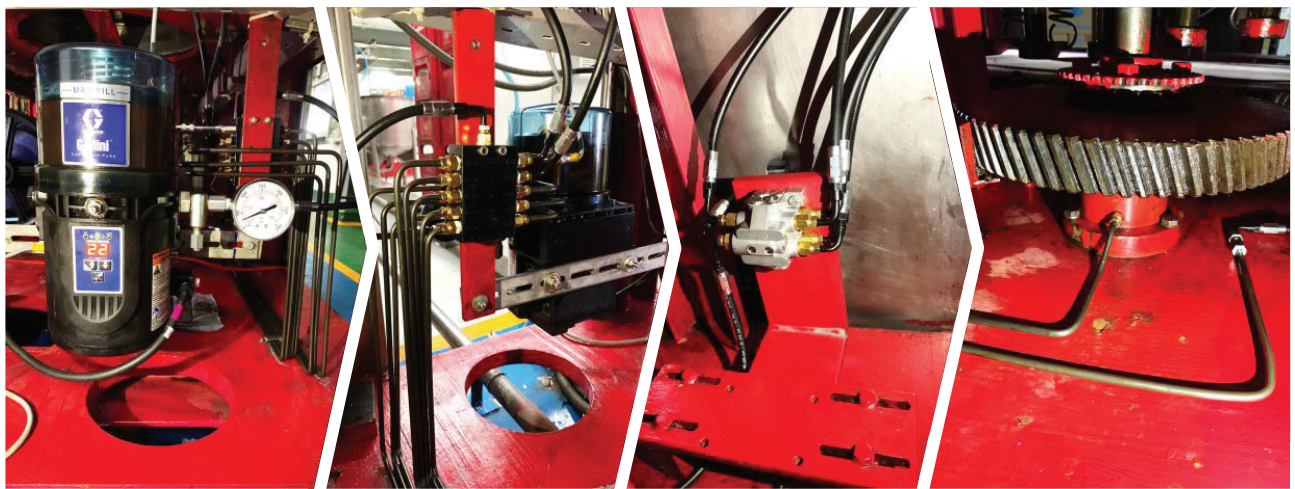
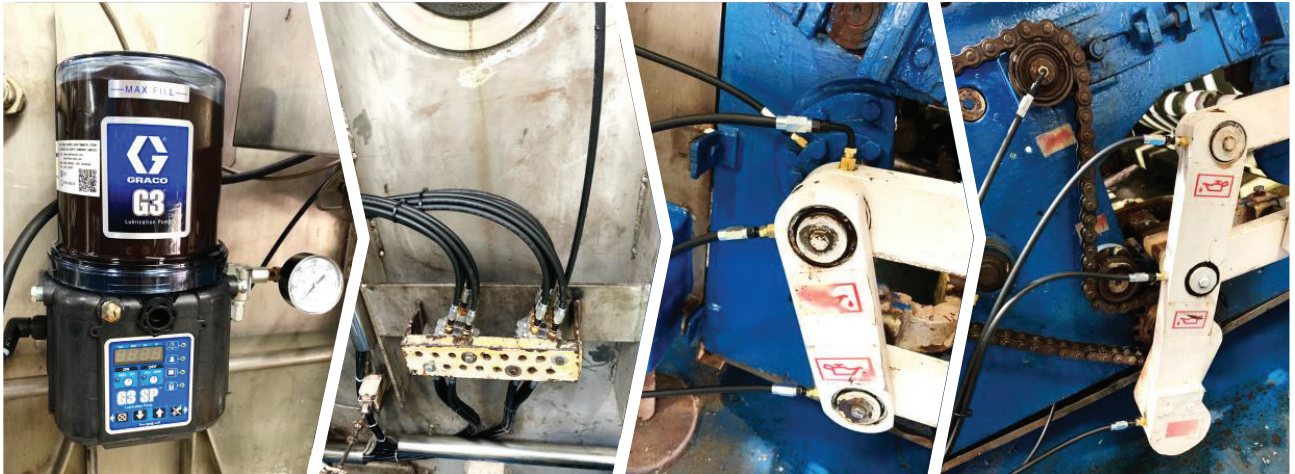



THE WORLD LEADING AUTOMATIC LUBRICATION SYSTEM

1. ควบคุมการอัดจารบีได้อย่างคงที่
2. ยืดอายุการทำงานของเครื่องจักร
3. ตรวจสอบบำรุงรักษาได้ง่าย
4. ลดการสิ้นเปลืองจารบีที่อัดเยอะเกินไป
5. ตรวจสอบปริมาณการอัดจารบีในแต่ละจุดได้อย่างแม่นยำ
6. สามารถกำหนด timing ได้ 52 setting
7. EX Proof และ IP66
8. ไม่มีอุปกรณ์ LED และอิเล็กทรอนิกส์ ป้องกันประกายไฟและ
สั้นสะท้อน เพื่อการทนทานของอุปกรณ์
9. Battery 2A ALKALINE ราคาถูก หาซื้อได้ง่าย
10. Refills จารบีราคาถูก



A powerful and efficient pump

- 4.5V Batteries
(Optional external 24 V power supply)
แบตเตอรี่ 4.5V
(อุปกรณ์เสริม แหล่งจ่ายไฟ 24 โวลต์)
- Dosing pump with Adjustable Output.
ปั๊มหัวจ่ายแบบปรับได้

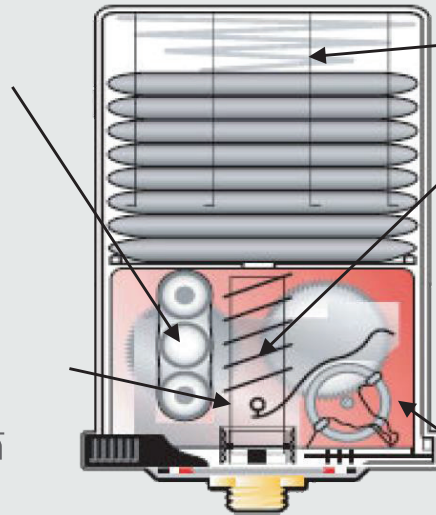

- Compression spring สปริงอัด
- Ejection spring 25 bar สปริงดีดออก 25 บาร์

Lever : On the gearbox

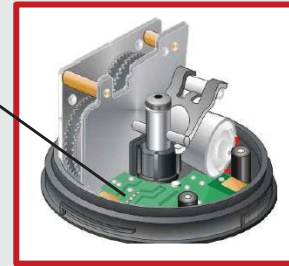

- ✓ Dosing pump with adjustable output.
- ✓ Lubricant ejection pressure of 25 bar.
- ✓ High-performance pump able to pump lubricants at extreme temperatures and with high viscosity.

Manual greasing

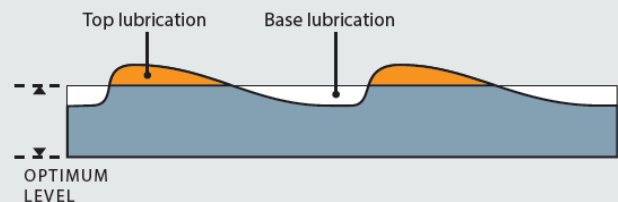
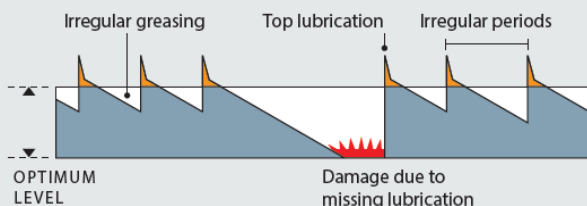

Lubrication with MEMOLUB

Accurate greasing, frequently and regularly

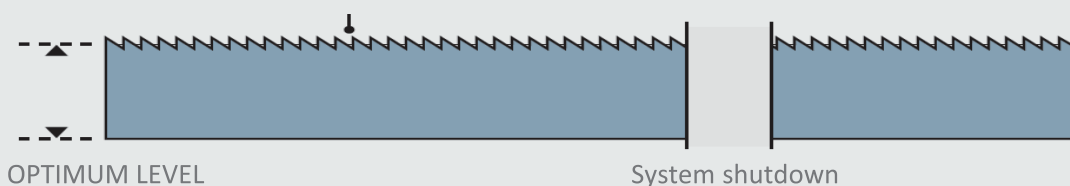



A powerful and efficient pump

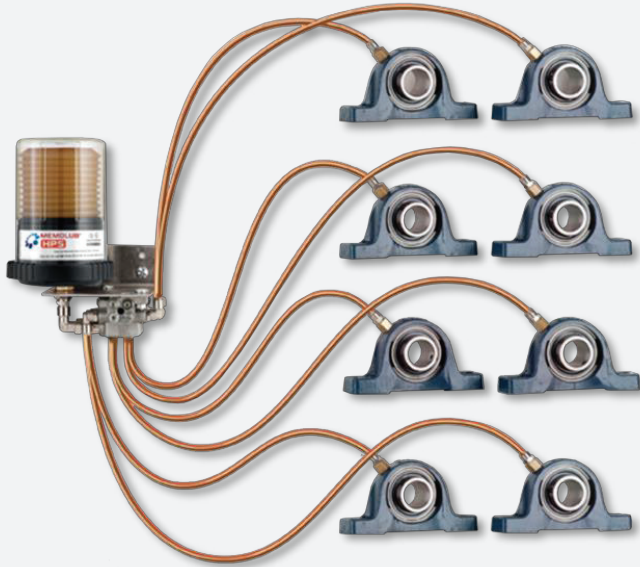

Distributor Kits
ตรวจสอบได้โดย Memolub

- ✓ MEMOLUB บล็อกแบ่งปริมาณน้ำมันหล่อลื่นอย่างสม่ำเสมอในแต่ละรอบการขับออก Output ที่เท่ากัน (0.3cc)
- ✓ ทำความสะอาดง่าย
- ✓ แรงดันสูงทำงานอย่างต่อเนื่อง
- ✓ สูงสุด 8 จุด และ 8 เมตร
- ✓ ไม่สูญเสียแรงดัน

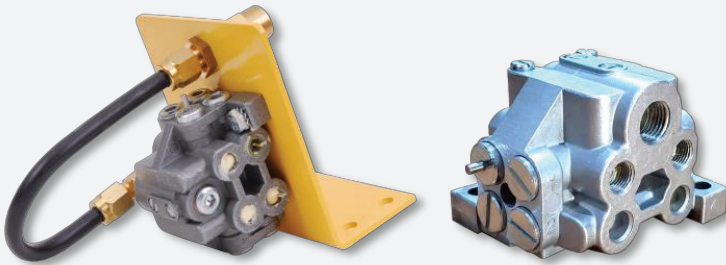

CE IP66 MEMOLUB INTERNATIONAL S.A.
MADE IN BELGIUM

มีอะไหล่เปลี่ยนทุกชิ้น

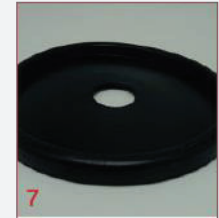

Installation Glove Factory



Installation Robot System



Installation Robot System



Installation Recycle Line

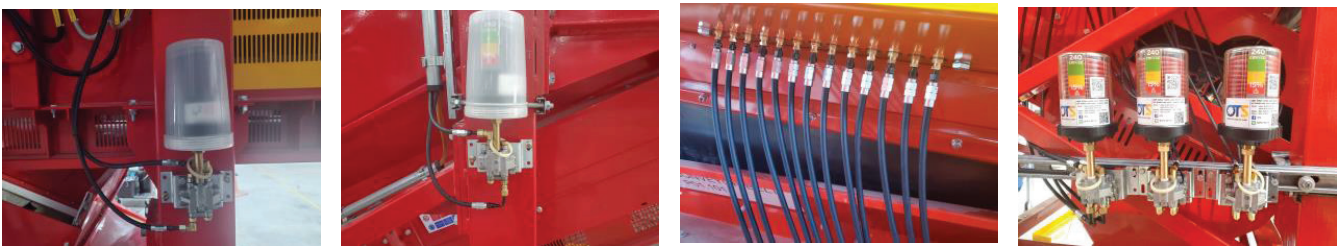

Other Application

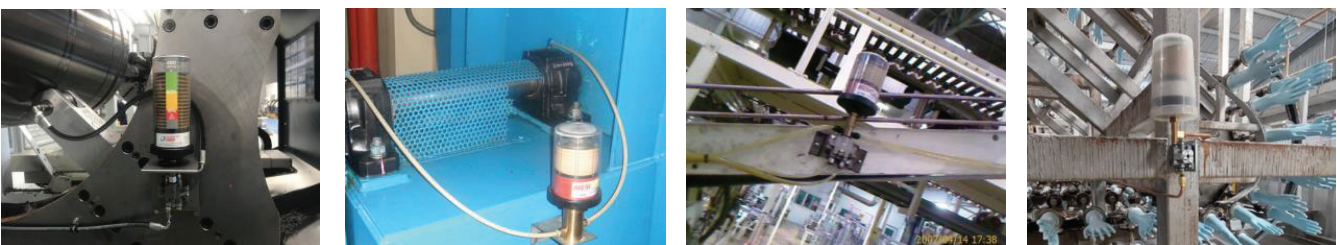

โครงการติดตั้งท่อ Duct

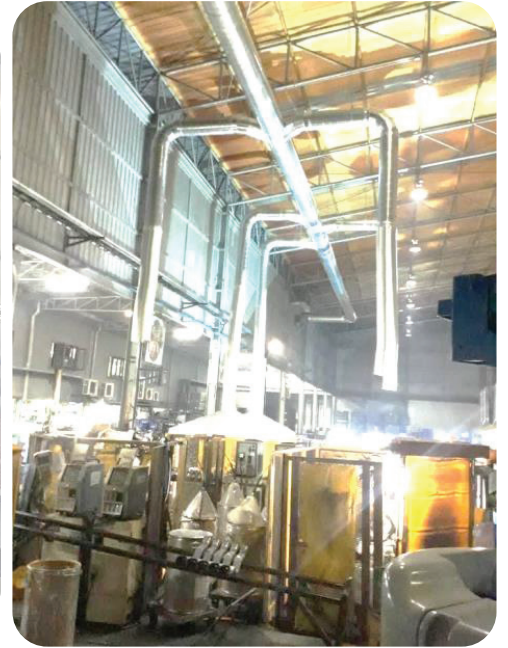

”

โครงการก่อสร้าง Cooling Tower



”

โครงการขนย้ายและติดตั้งเครื่องจักร



”

โครงการซ่อมและตรวจเช็คเครื่องปั๊มโลหะ



”

โครงการติดตั้งเครื่องจักร

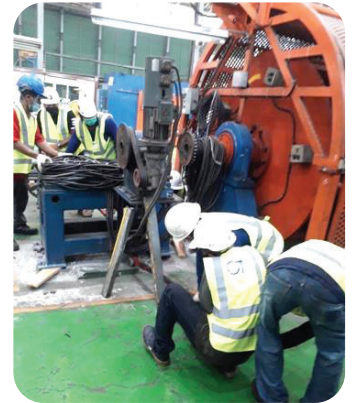

”

โครงการติดตั้งเครื่องจักร

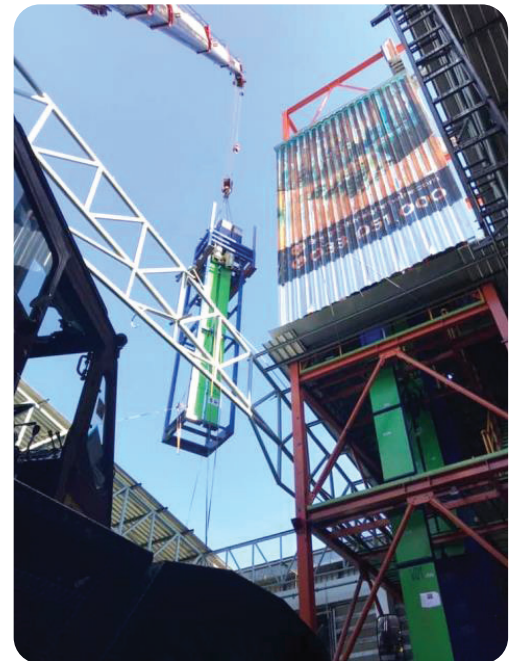

”

โครงการติดตั้งไฟส่องสว่าง

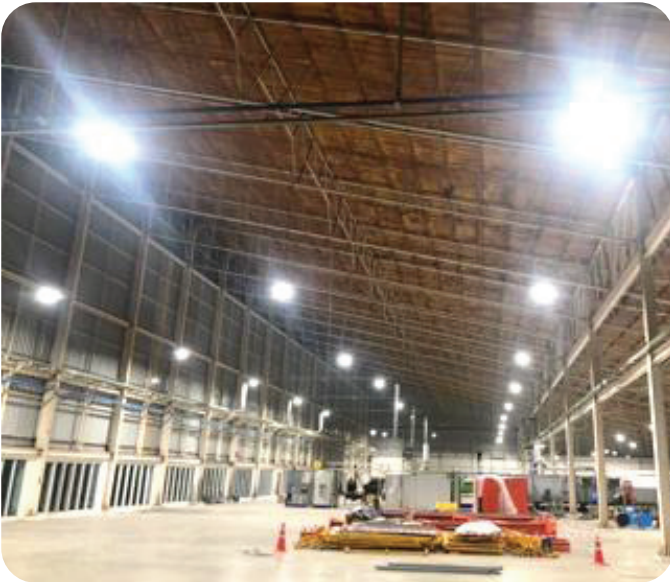

”

โครงการติดตั้งตู้ MDB และเดินสายไฟแรงสูง แรงต่ำ



”

โครงการติดตั้งท่อ UPVC



”

โครงการติดตั้งท่อ UPVC ใน อุตสาหกรรมปิโตรเคมี



”

โครงการทำถังอุตสาหกรรม



”

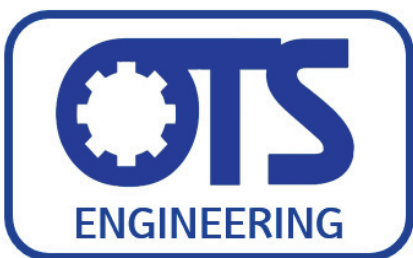

Quality
Ethics & Integrity
Safety
Standard



WWW.OTSINDUSTRIAL.COM

Line Official: @ots-belts

